

2.0L DOHC 4-CYL - VINS [R,U]

Article Text

1991 Mitsubishi Eclipse

For chip

Copyright © 1998 Mitchell Repair Information Company, LLC

Tuesday, March 27, 2001 05:52PM

ARTICLE BEGINNING

1991 ENGINES

Mitsubishi - 2.0L DOHC (VINS R & U) 4-Cylinder

Eclipse, Galant

* PLEASE READ THIS FIRST *

NOTE: For engine repair procedures not covered in this article, see ENGINE OVERHAUL PROCEDURES - GENERAL INFORMATION article in the GENERAL INFORMATION section.

ENGINE IDENTIFICATION

Vehicle Identification Number (VIN) is stamped on a metal plate located at upper left corner of instrument panel, near windshield. The eighth character of VIN identifies engine and tenth character (M) identifies model year (1991).

Engine model code and serial number are stamped on right side of cylinder block, near front. For specific location, see the A - ENGINE/VIN ID article in ENGINE PERFORMANCE.

ENGINE IDENTIFICATION CODE TABLE

AA

Application	Engine Code	VIN Code
2.0L DOHC 4-Cylinder		
Non-Turbo	4G63	R
Turbo	4G63	U

AA

ADJUSTMENTS

VALVE CLEARANCE ADJUSTMENT

Hydraulic lash adjusters are used. Valve adjustment is not required.

REMOVAL & INSTALLATION

NOTE: For reassembly reference, label all electrical connectors, vacuum hoses and fuel lines before removal. Also place mating marks on engine hood and other major assemblies before removal.

FUEL PRESSURE RELEASE

Disconnect fuel pump connector near fuel tank. Start engine, and allow it to idle until it stalls. Turn ignition off. Reconnect

2.0L DOHC 4-CYL - VINS [R,U]

Article Text (p. 2)

1991 Mitsubishi Eclipse

For chip

Copyright © 1998 Mitchell Repair Information Company, LLC

Tuesday, March 27, 2001 05:52PM

fuel pump connector. Disconnect negative battery cable before disconnecting fuel lines.

ENGINE

CAUTION: To prevent fire hazard, release residual pressure in fuel system before disconnecting fuel lines.

Removal

- 1) Release residual fuel pressure from fuel system. See FUEL PRESSURE RELEASE under REMOVAL & INSTALLATION.
- 2) Remove hood. Drain cooling system. Drain engine oil and transaxle oil. Remove transaxle. On M/T models, see CLUTCH article. On A/T models, see the TRANSMISSION REMOVAL & INSTALLATION - A/T article in TRANSMISSION SERVICING.
- 3) Remove radiator and cooling fan assembly. Disconnect all necessary electrical connectors, vacuum hoses, fuel hoses and cables. Leaving hoses connected, remove power steering pump and A/C compressor, and support aside using wire.
- 4) Disconnect exhaust pipe from exhaust manifold. Using suitable lifting device, support weight of engine. Remove upper engine mount bracket assembly. Raise engine slightly. Ensure all cables, hoses and electrical harnesses are disconnected from engine. Lift engine upward from engine compartment.

Installation

To install, reverse removal procedure. Ensure all hoses and wires are cleared when lowering engine assembly into compartment. Perform final tightening of mounting bolts and nuts with weight of engine on insulators. See TORQUE SPECIFICATIONS table. Replace all fluids, and adjust all cables and linkages.

INTAKE MANIFOLD

CAUTION: To prevent fire hazard, release residual pressure in fuel system before disconnecting fuel lines.

Removal

- 1) Release residual fuel pressure from fuel system. See FUEL PRESSURE RELEASE under REMOVAL & INSTALLATION.
- 2) Disconnect negative battery cable. Drain cooling system. Disconnect air intake hose or turbo supply hose from throttle body inlet. Remove air cleaner assembly (if necessary).

CAUTION: DO NOT allow fuel injectors to fall out when removing fuel delivery pipe.

- 3) Disconnect all necessary electrical connectors, vacuum hoses, coolant hoses, fuel hoses and cables from intake manifold, injectors and throttle body. Remove delivery pipe with fuel injectors and pressure regulator attached. See Fig. 1.
- 4) Remove support brace from below intake manifold. Remove

2.0L DOHC 4-CYL - VINS [R,U]

Article Text (p. 3)

1991 Mitsubishi Eclipse

For chip

Copyright © 1998 Mitchell Repair Information Company, LLC

Tuesday, March 27, 2001 05:52PM

lower intake manifold-to-cylinder head bolts. Remove lower intake manifold and gasket. If necessary, remove remaining components from intake manifold.

Installation

To install, reverse removal procedure using new gaskets, fuel injector insulators and "O" rings. Adjust all control cables, and fill cooling system.

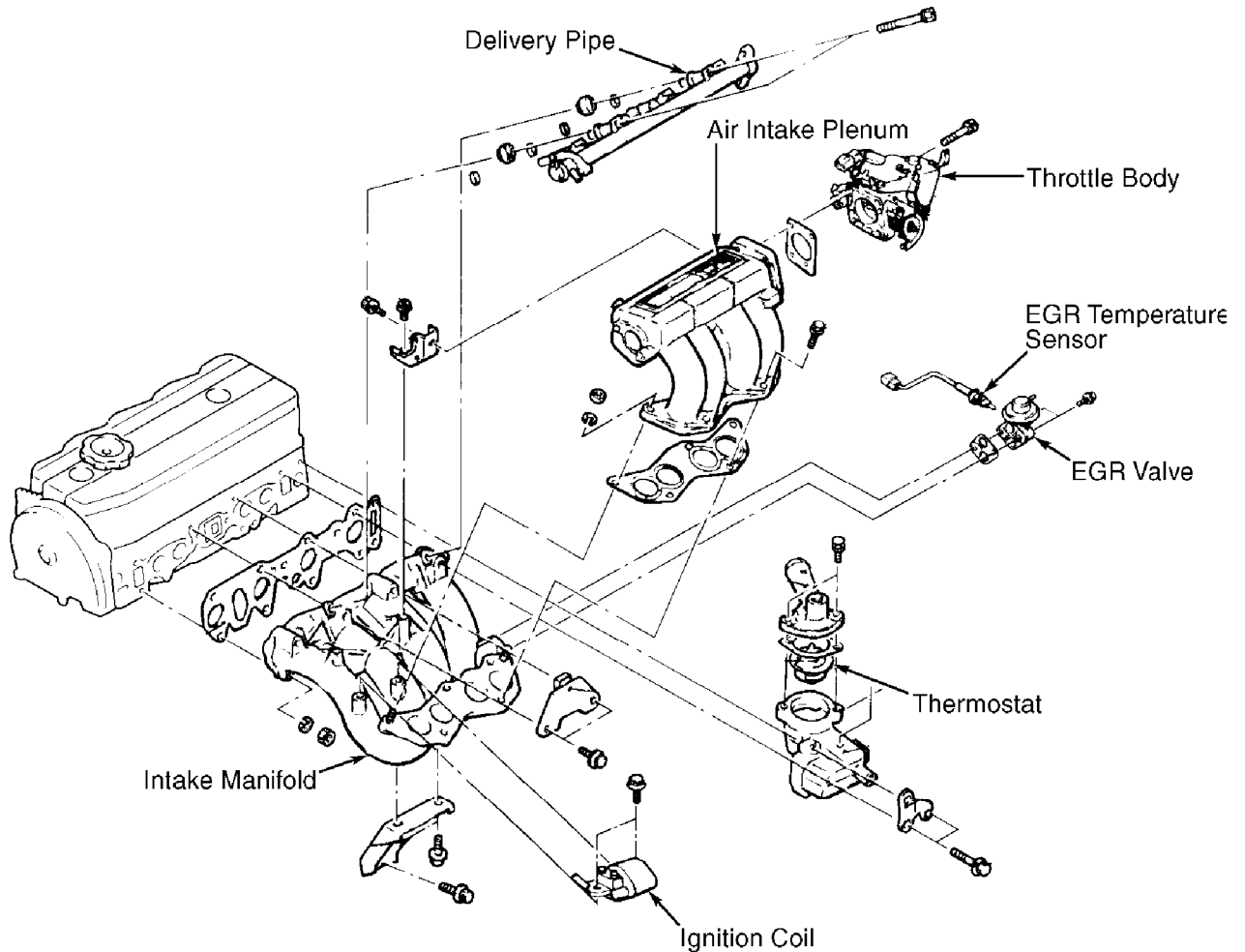

92E00004

Fig. 1: Exploded View of Intake Manifold & Related Components
Courtesy of Mitsubishi Motor Sales of America.

EXHAUST MANIFOLD

Removal (Non-Turbo)

On vehicles equipped with A/C, remove condenser fan motor assembly. On all models, disconnect exhaust pipe and gasket from manifold. Remove outer heat shield from manifold. Disconnect oxygen sensor. Remove manifold.

Installation (Non-Turbo)

2.0L DOHC 4-CYL - VINS [R,U]

Article Text (p. 4)

1991 Mitsubishi Eclipse

For chip

Copyright © 1998 Mitchell Repair Information Company, LLC

Tuesday, March 27, 2001 05:52PM

To install, reverse removal procedure using new gaskets. Install new manifold nuts and exhaust pipe-to-manifold nuts.

NOTE: For Turbo, removal and installation procedure for exhaust manifold includes removal and installation of turbo.

Removal (Turbo)

1) Drain engine coolant and engine oil. Remove condenser fan assembly. On Galant models, remove radiator. On all models, disconnect and remove oxygen sensor. Remove dipstick tube.

2) Disconnect air intake hose from turbo. Disconnect vacuum hose from turbo wastegate valve. See Fig. 2. Disconnect boost pressure signal line from turbo output hose.

3) Disconnect turbo output hose from turbo. Remove upper and lower heat shields from manifold. Remove power steering pump with hoses connected, and support aside. Remove power steering pump bracket and engine hanger.

4) Disconnect water hose from water pipe "A". Disconnect water pipe "B" from engine (flare nut fitting). See Fig. 2. Remove oil pressure and oil return pipes from between engine and turbo. Disconnect exhaust pipe from turbo. Remove turbo and exhaust manifold assembly. Separate turbo from exhaust manifold.

Installation (Turbo)

To install, reverse removal procedure. Use new gaskets, manifold nuts and exhaust pipe-to-turbo nuts. Refill all necessary fluids.

CAUTION: Apply light oil to inner surface of flared area on water pipe (flare nut fitting) before connecting to engine.

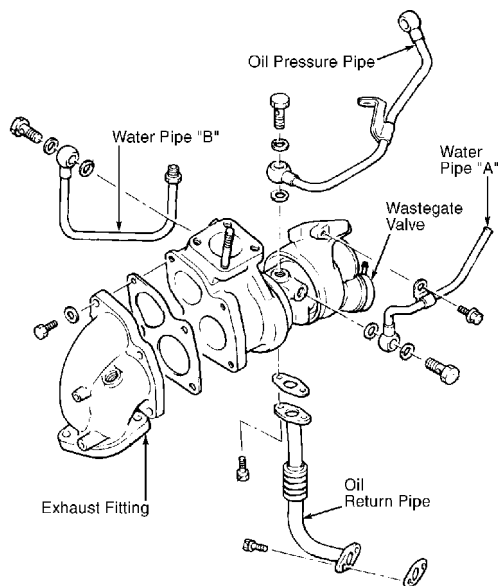

91E00814
Fig. 2: Exploded View of Turbocharger Assembly
Courtesy of Mitsubishi Motor Sales of America.

2.0L DOHC 4-CYL - VINS [R,U]

Article Text (p. 5)

1991 Mitsubishi Eclipse

For chip

Copyright © 1998 Mitchell Repair Information Company, LLC

Tuesday, March 27, 2001 05:52PM

TURBOCHARGER

NOTE: For turbocharger removal and installation procedures, see EXHAUST MANIFOLD under REMOVAL & INSTALLATION.

Disassembly

- 1) Loosen coupling, and separate turbine housing from cartridge assembly and compressor cover. See Fig. 3.
- 2) Place compressor cover on solid surface, with turbine facing up. Cover snap ring using finger (preventing spring force from ejecting it), and remove snap ring.
- 3) Hold turbine stationary with one hand and tap compressor cover using a plastic mallet to separate components. Some resistance will be felt due to "O" ring inside cartridge assembly.

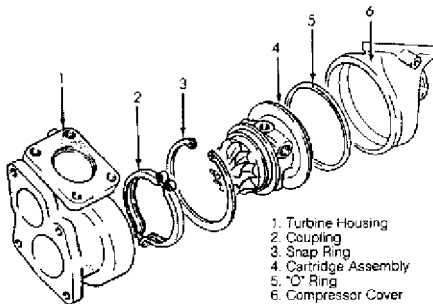

Fig. 3: Exploded View of Turbine Assembly
Courtesy of Mitsubishi Motor Sales of America.

Inspection

- 1) Inspect turbine housing and blades for cracks and damage. Ensure turbine rotates freely and turbine blades do not contact housing. Ensure wastegate valve operates freely. Ensure oil passage in cartridge assembly is clear.
- 2) Leak test wastegate valve actuator diaphragm using a hand-held vacuum pump. If testing wastegate actuator operation by applying pressure to diaphragm, DO NOT apply more than 12.4 psi to diaphragm.

CAUTION: Oil leakage could result if new "O" ring is damaged when installing into groove on cartridge assembly.

Reassembly

- 1) Coat new "O" ring with oil, and install into groove on cartridge assembly. Be careful to prevent damage to "O" ring during installation. Align dowel pin on compressor cover with hole in cartridge assembly, and install cartridge assembly onto compressor cover. Install snap ring with chamfered outer edge of snap ring facing away from compressor cover.
- 2) Align dowel pin on turbine housing with hole in cartridge assembly, and install compressor cover and cartridge assembly onto turbine housing. Tighten coupling. Supply clean engine oil through oil pressure pipe inlet hole in cartridge assembly.

CYLINDER HEAD

2.0L DOHC 4-CYL - VINS [R,U]

Article Text (p. 6)

1991 Mitsubishi Eclipse

For chip

Copyright © 1998 Mitchell Repair Information Company, LLC

Tuesday, March 27, 2001 05:52PM

CAUTION: Release residual pressure in fuel system before disconnecting fuel lines. To compensate for removal of left engine mount, support oil pan to maintain level engine while working on engine.

Removal

1) Release residual fuel pressure from fuel system. See FUEL PRESSURE RELEASE under REMOVAL & INSTALLATION.

2) Drain cooling system. Remove air cleaner assembly. Disconnect all necessary electrical connectors, vacuum hoses, coolant hoses, fuel hoses and cables. Remove timing belt. See TIMING BELT under REMOVAL & INSTALLATION.

3) Remove rocker cover. On non-turbo engines, disconnect exhaust pipe from exhaust manifold. On turbo engines, disconnect exhaust manifold from turbo.

4) On all models, loosen cylinder head bolts (in 2-3 steps) in proper sequence using Cylinder Head Bolt Wrench (MD998051). See Fig. 4. Remove cylinder head and gasket.

Inspection

Inspect cylinder head for warpage at deck surface. Resurface cylinder head if warpage exceeds specification. See CYLINDER HEAD table under ENGINE SPECIFICATIONS.

Installation

1) Install cylinder head using new gasket. Ensure identification mark at timing belt end of gasket faces upward. DO NOT apply sealant to head gasket. Install and tighten cylinder head bolts (in 2-3 steps) to specification in proper sequence. See Fig. 4.

2) To complete installation, reverse removal procedure. Apply sealant to contact surfaces of semi-circular packing. Apply gasoline to "O" ring on fuel line before installing fuel line in fuel delivery pipe. Adjust all control cables. Fill cooling system.

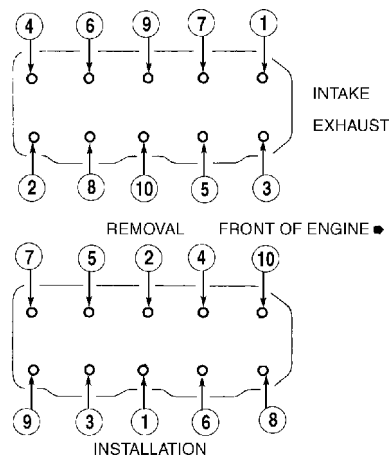

Fig. 4: Cylinder Head Bolt Removal & Installation
Courtesy of Chrysler Motors.

2.0L DOHC 4-CYL - VINS [R,U]

Article Text (p. 7)

1991 Mitsubishi Eclipse

For chip

Copyright © 1998 Mitchell Repair Information Company, LLC

Tuesday, March 27, 2001 05:52PM

FRONT COVER OIL SEAL

NOTE: Front cover refers to cover at front of cylinder block. Cover contains oil pump and front cover oil seal (crankshaft front seal). Manufacturer lists oil seal removal procedure with front cover removed from engine. See OIL PUMP & FRONT COVER under ENGINE OILING.

TIMING BELT

CAUTION: To prevent engine damage, DO NOT rotate crankshaft counterclockwise (as viewed from timing belt end of engine).

Removal

It may be convenient to raise the vehicle on a hoist to a level where work can be performed through the wheel well and over the top of the fender.

- 1) Remove lower left engine compartment splash shield.
- 2) Support engine with engine support fixture, tool #C4852 or #7137, and remove the left engine mount and bracket. See Fig. 5.

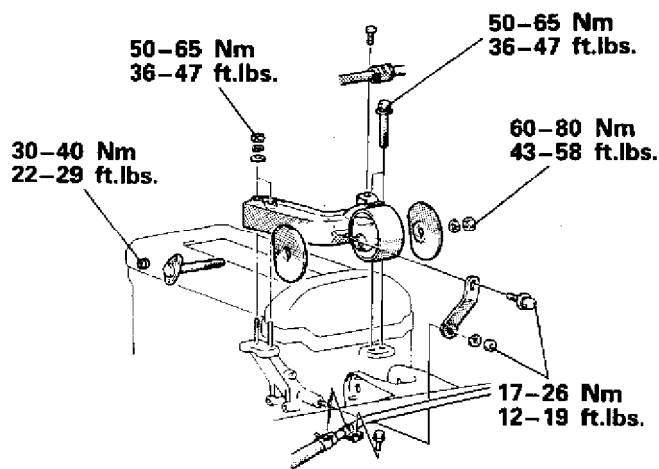

94D50040

Fig. 5: Left Engine Mount Assembly
Courtesy of Mitsubishi Motor Sales of America.

3) Loosen the water pump pulley bolts. Remove the alternator/water pump drive belts, and the power steering drive belt.

NOTE: Loosen water pump pulley bolts before removing belt.

4) Remove water pump pulley. Remove the tensioner pulley bracket and the A/C belt. Remove crankshaft pulley. Remove the upper and lower timing belt covers.

5) Rotate the crankshaft clockwise and align the timing marks so as to bring the No. 1 piston to the Top-Dead-Center (TDC) position

2.0L DOHC 4-CYL - VINS [R,U]

Article Text (p. 8)

1991 Mitsubishi Eclipse

For chip

Copyright © 1998 Mitchell Repair Information Company, LLC

Tuesday, March 27, 2001 05:52PM

of the compression stroke.

CAUTION: Rotate the crankshaft in a clockwise direction.

6) The camshaft sprocket dowel pins must be at the 12 o'clock position and the camshaft sprocket timing marks must be aligned together (left sprocket at the 3 o'clock and right sprocket at the 9 o'clock positions). Both camshaft sprocket timing marks must be in line with the top surface of the cylinder head. See Fig. 6. A straight edge (ruler) laid across the center of the camshaft attaching bolts will help you to better see and align the timing marks. The crankshaft and oil pump sprockets must also be aligned with their respective timing marks. See Fig. 7.

NOTE: Crankshaft may need to be rotated up to six turns before all sprockets are properly aligned and the rear balance shaft is in phase, due to the oil pump-to balance shaft gear ratio.

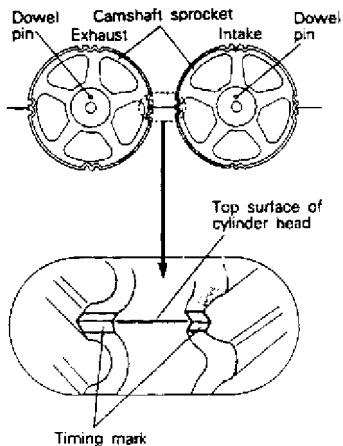

Fig. 6: Camshaft Sprocket Timing Marks Alignment
Courtesy of Mitsubishi Motor Sales of America.

2.0L DOHC 4-CYL - VINS [R,U]

Article Text (p. 9)

1991 Mitsubishi Eclipse

For chip

Copyright © 1998 Mitchell Repair Information Company, LLC

Tuesday, March 27, 2001 05:52PM

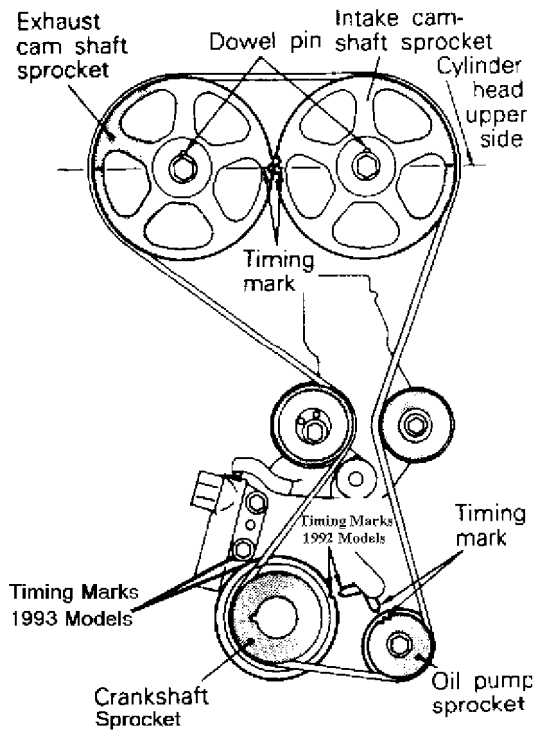

94E50041

Fig. 7: Crankshaft Timing Marks Alignment
Courtesy of Mitsubishi Motor Sales of America.

7) Remove rubber plug from inner timing belt cover and screw special tool no. MD998738 into the engine left support bracket until it makes contact with the tensioner arm. See Figs. 8 & 9.

8) Loosen the tensioner pulley center bolt. See Fig. 9.

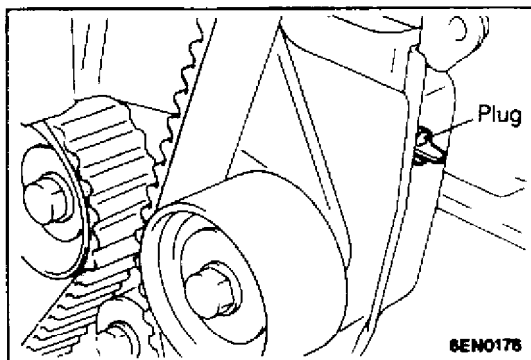

94F50042

Fig. 8: Rubber Plug Location
Courtesy of Mitsubishi Motor Sales of America.

2.0L DOHC 4-CYL - VINS [R,U]

Article Text (p. 10)

1991 Mitsubishi Eclipse

For chip

Copyright © 1998 Mitchell Repair Information Company, LLC

Tuesday, March 27, 2001 05:52PM

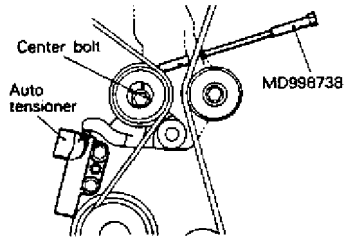

Fig. 9: Auto Tensioner Assembly
Courtesy of Mitsubishi Motor Sales of America.

9) Compress the Auto Tensioner push rod by SLOWLY rotating special tool no. MD998738 until hole in Auto Tensioner push rod aligns with the hole in the Auto Tensioner body. See Fig. 10.

NOTE: Push rod may need to be rotated if hole in rod is not vertically in line with hole in housing.

10) Insert a 1/16" Allen wrench or similar pin [1.4 mm (.055") in diameter into the aligned holes to hold the push rod in the reset (pinned) position. Back off special tool MD998738 once auto tensioner is in the reset position. See Fig. 10.

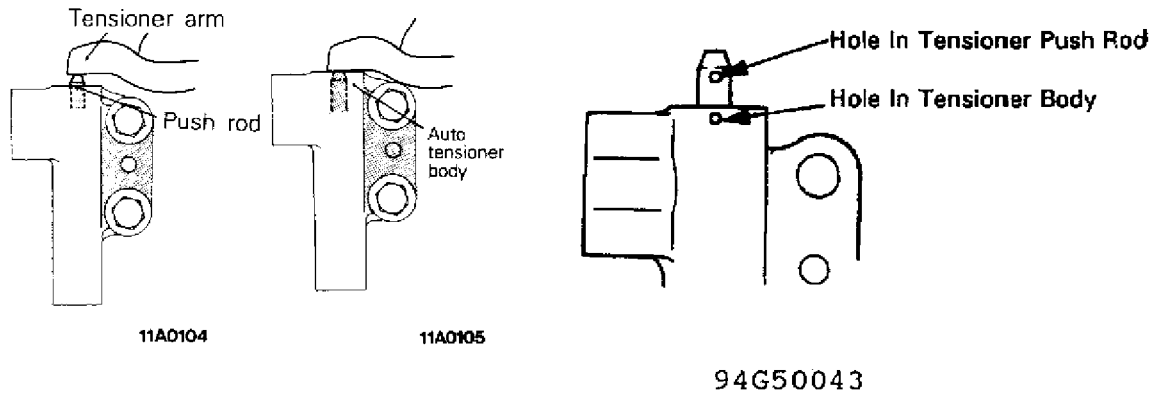

Fig. 10: Compressing Auto Tensioner Push Rod
Courtesy of Mitsubishi Motor Sales of America.

NOTE: Inspect the tensioner and replace it if it shows signs of oil leakage.

2.0L DOHC 4-CYL - VINS [R,U]

Article Text (p. 11)

1991 Mitsubishi Eclipse

For chip

Copyright © 1998 Mitchell Repair Information Company, LLC
Tuesday, March 27, 2001 05:52PM

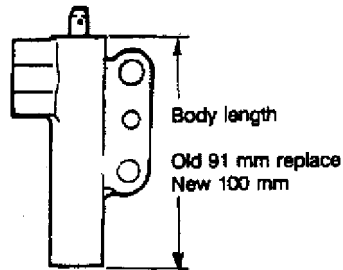

94H50044

Fig. 11: Auto Tensioner Body Length
Courtesy of Mitsubishi Motor Sales of America.

11) Remove and discard the camshaft timing belt. Loosen timing belt "B" tensioner pulley center bolt. See Fig. 12. Remove and discard timing belt "B".

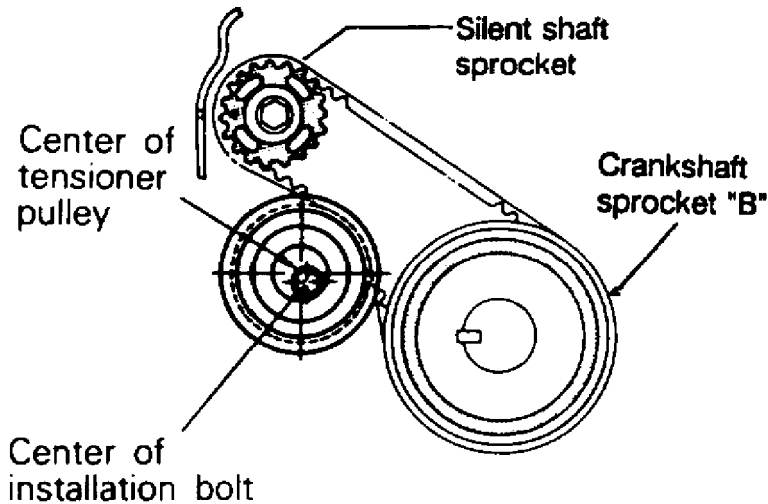

94I50045

Fig. 12: Tensioner Pulley and Center Bolt
Courtesy of Mitsubishi Motor Sales of America.

Installation

1) Ensure that the crankshaft sprocket and the silent shaft sprocket timing marks are aligned. Install new timing belt "B" over crankshaft sprocket "B", around the tensioner pulley, and over the silent shaft sprocket. Do not leave any slack on the tension side of the belt. See Fig. 13.

2.0L DOHC 4-CYL - VINS [R,U]

Article Text (p. 12)

1991 Mitsubishi Eclipse

For chip

Copyright © 1998 Mitchell Repair Information Company, LLC

Tuesday, March 27, 2001 05:52PM

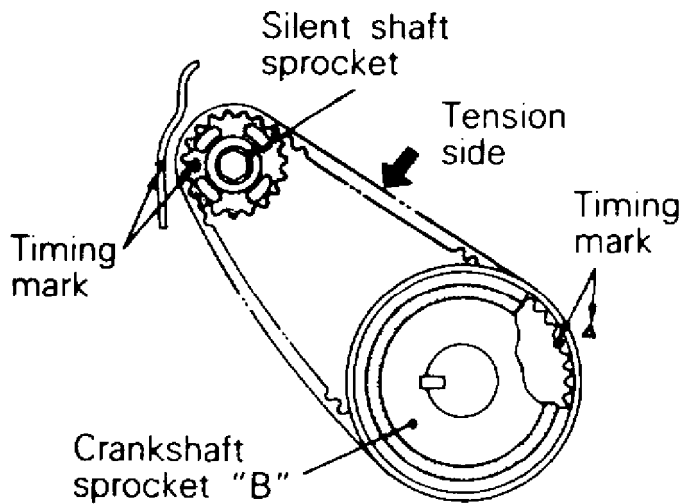

94J50046 1990-1992 Models

Fig. 13: Crankshaft Sprocket "B" Timing Marks Alignment
Courtesy of Mitsubishi Motor Sales of America.

2) Push the timing belt "B" tensioner up to place pressure on the timing belt so that the tension side is taut. Belt tension should be 5-7 mm (.20-.28 in.) using the belt deflection method. Tighten the tensioner center bolt and torque to 15-22 Nm (11-16 in.lbs.). See Fig. 12.

CAUTION: When tightening the bolt, ensure that the tensioner pulley shaft does not rotate with the bolt. Allowing it to rotate can cause excessive tension on the belt.

3) Rotate the camshaft timing belt tensioner pulley so that the pinholes are to the left of the center bolt. Tighten the center bolt finger-tight. See Fig. 9.

NOTE: Leave the Allen wrench installed in the auto tensioner.

4) Make sure the camshaft sprocket dowel pins are located at the 12 o'clock position and the camshaft sprocket timing marks are aligned together (left sprocket at the 3 o'clock and right sprocket at the 9 o'clock positions). Both camshaft sprocket timing marks should be in line with the top surface of the cylinder head. See Fig. 6.

NOTE: The exhaust camshaft sprocket may rotate in the counter-clockwise direction. This should be considered when installing the timing belt.

5) Make sure that the crankshaft sprocket and the oil pump sprocket is aligned with the timing mark pointers. See Fig. 14.

2.0L DOHC 4-CYL - VINS [R,U]

Article Text (p. 13)

1991 Mitsubishi Eclipse

For chip

Copyright © 1998 Mitchell Repair Information Company, LLC

Tuesday, March 27, 2001 05:52PM

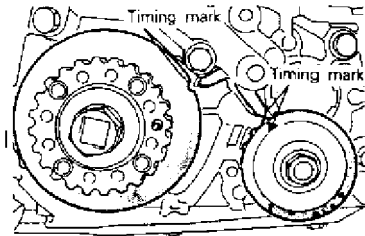

Fig. 14: Crankshaft, Oil Pump Sprockets Timing Marks
Courtesy of Mitsubishi Motor Sales of America.

6) Remove the balance shaft plug on the rear side of the cylinder block and insert a Phillips screwdriver [shank diameter 8 mm (.31 in.)] through the hole. The balance shaft is in the correct position if the screwdriver can be inserted at least 60 mm (2.4"). If the inserted depth is less than this only 20-25 mm (.8-1.0"), the oil pump sprocket must be rotated one full turn and timing marks realigned. Recheck the balance shaft position using the screwdriver to ensure that it can be inserted 60 mm (2.4") or more. Keep the screwdriver inserted until timing belt installation is complete. See Fig. 15.

CAUTION: Make sure the balance shaft is properly positioned. It is possible for the oil pump sprocket timing marks to be properly aligned, and have the balance shaft out of phase. This could result in a SEVERE engine vibration.

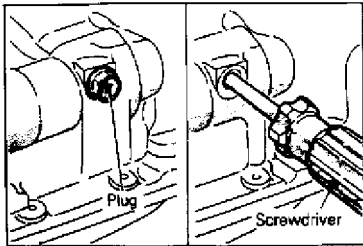

Fig. 15: Checking Balance Shaft Position
Courtesy of Mitsubishi Motor Sales of America.

7) Install the new timing belt over the intake side camshaft sprocket and clamp it in position with a clip. See Fig. 16.

2.0L DOHC 4-CYL - VINS [R,U]

Article Text (p. 14)

1991 Mitsubishi Eclipse

For chip

Copyright © 1998 Mitchell Repair Information Company, LLC

Tuesday, March 27, 2001 05:52PM

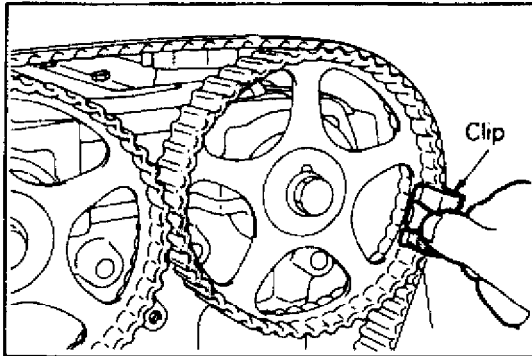

94C50049

Fig. 16: Clipping Timing Belt to Intake Camshaft Sprocket
Courtesy of Mitsubishi Motor Sales of America.

8) Use a wrench to maintain alignment of the two camshafts and install the timing belt over the exhaust side sprocket, aligning the timing marks (as shown in Fig. 6) and clamp the belt in position with a clip. See Figs. 17 and 18.

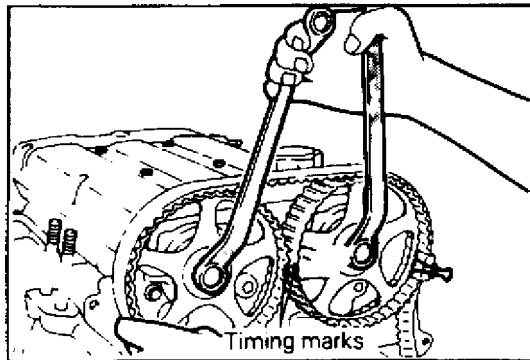

94G50050

Fig. 17: Maintaining Camshafts Alignment
Courtesy of Mitsubishi Motor Sales of America.

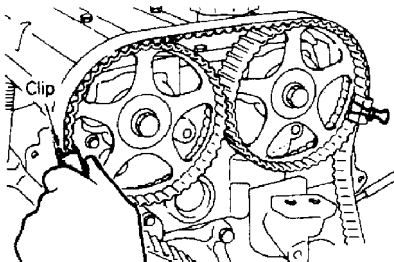

94H50051

Fig. 18: Clipping Timing Belt to Exhaust Camshaft Sprocket
Courtesy of Mitsubishi Motor Sales of America.

2.0L DOHC 4-CYL - VINS [R,U]

Article Text (p. 15)

1991 Mitsubishi Eclipse

For chip

Copyright © 1998 Mitchell Repair Information Company, LLC

Tuesday, March 27, 2001 05:52PM

9) Position the timing belt around the idler pulley, oil pump sprocket, crankshaft sprocket and tensioner pulley (in that order) as shown in Fig. 19.

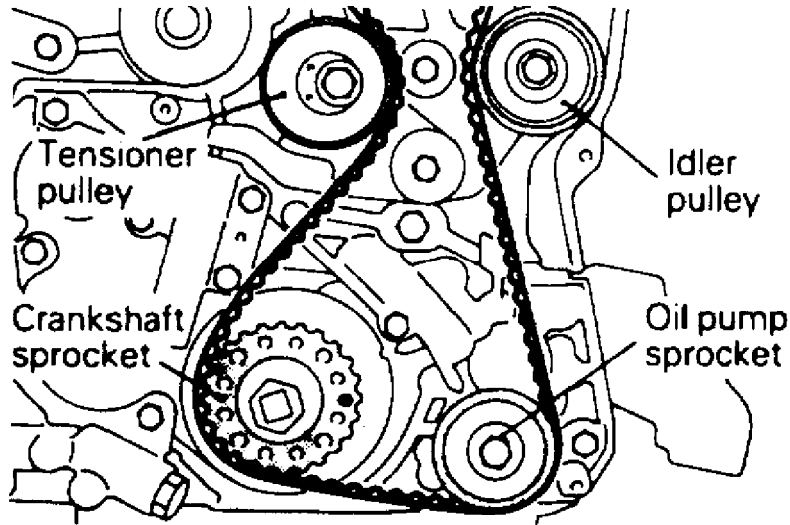

94I50052

Fig. 19: Timing Belt Position on Crankshaft/Oil Pump Sprockets
Courtesy of Mitsubishi Motor Sales of America.

10) Rotate the tensioner pulley in a clockwise direction and tighten the center bolt. See Fig. 20.

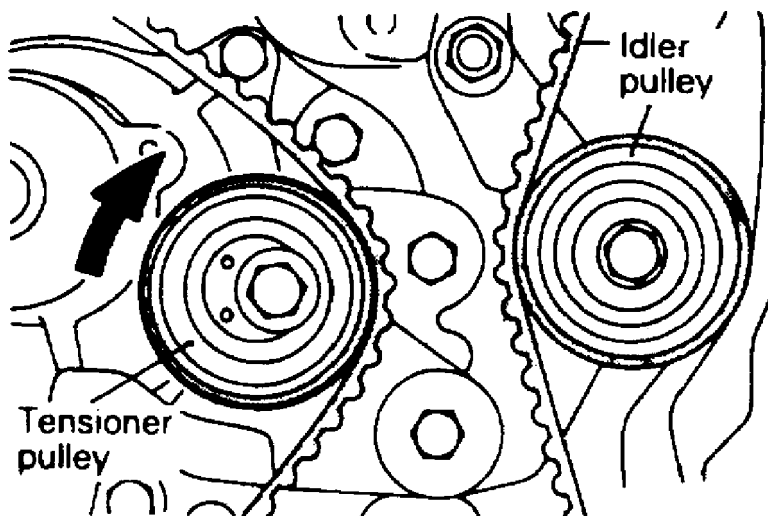

94J50053

Fig. 20: Tensioner Pulley Rotation
Courtesy of Mitsubishi Motor Sales of America.

2.0L DOHC 4-CYL - VINS [R,U]

Article Text (p. 16)

1991 Mitsubishi Eclipse

For chip

Copyright © 1998 Mitchell Repair Information Company, LLC

Tuesday, March 27, 2001 05:52PM

NOTE: Make sure all timing belt teeth are engaged with the teeth on the camshafts, oil pump, and crankshaft sprockets and that all timing marks are still properly aligned.

11) Remove the oil pump sprocket nut and check the condition of the nut. Replace it if necessary. If the condition of the nut is OK, clean and lubricate the threads, torque to 55 Nm (40 ft. lbs.) See Fig. 19.

12) Remove the screwdriver from the balance shaft hole and install the plug. Remove the two clips holding the belt to the camshaft sprockets.

13) Rotate the crankshaft a 1/4 turn counterclockwise, then rotate it clockwise until the timing marks are aligned again. Crankshaft position should still be at the No. 1 cylinder TDC position of the compression stroke.

NOTE: Make sure that all of the timing marks are still aligned.

14) Loosen the tensioner pulley center bolt, attach Special Tool No. MD998767 (or MD998752) and apply 2.7 Nm (24 in.lbs.) torque to pulley (with beam type torque wrench) as shown in Fig. 21 with torque applied to the tensioner pulley, tighten the attaching bolt, then torque to 49 \pm 6 Nm (36 \pm 4 ft. lbs.).

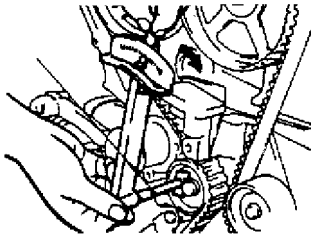

Fig. 21: Adjusting Belt Tension
Courtesy of Mitsubishi Motor Sales of America.

CAUTION: Failure to follow this procedure will cause the belt tension to exceed the range of the auto tensioner limits and result in premature timing belt failure or jumping.

NOTE: If the vehicle body interferes with the special tool and the torque wrench, raise the engine up slightly until there is adequate clearance.

15) Slowly rotate the Special Tool No. MD998738 until it makes contact with the tensioner arm and remove the Allen wrench from the auto tensioner. See Fig. 22.

2.0L DOHC 4-CYL - VINS [R,U]

Article Text (p. 17)

1991 Mitsubishi Eclipse

For chip

Copyright © 1998 Mitchell Repair Information Company, LLC

Tuesday, March 27, 2001 05:52PM

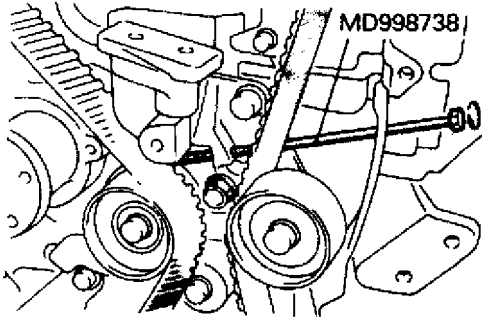

94A50054

Fig. 22: Special Tool MD998738 Installed

16) Back off the special tool and rotate the crankshaft six complete turns clockwise.

17) Measure the auto tensioner push rod position with a drill bit (distance between the tensioner arm and auto tensioner body) to ensure that it falls within the specification of 3.8-4.5 mm (.15-.18 in.) as shown in Fig. 23.

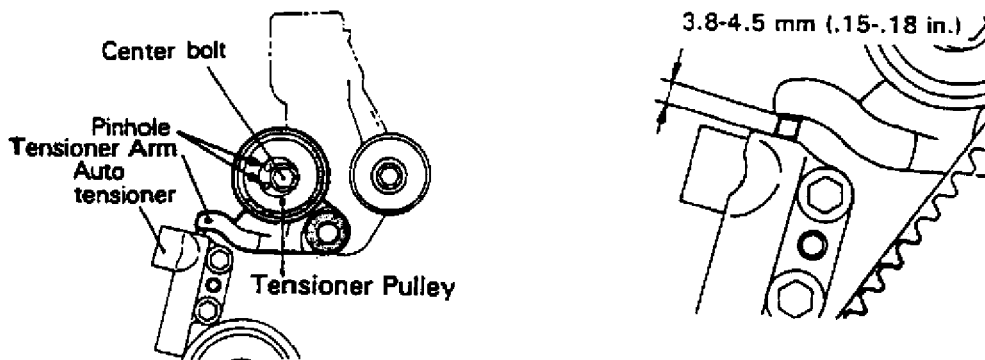

94B50055

Fig. 23: Auto Tensioner Push Rod Position Measurement
Courtesy of Mitsubishi Motor Sales of America.

NOTE: Wait 15 minutes after the Allen wrench is removed from auto tensioner (for plunger rod to stabilize) before measuring. If the plunger rod is out of specification, reset the auto tensioner (Steps 10, 11 and 12) and repeat Steps 29 through 32 until the specified value is obtained.

18) Remove special tool no. MD998738 and install the rubber plug to the inner timing belt cover.

19) Install the upper and lower timing belt covers assembly. (Rotate the bottom of the lower cover toward the rear to assist in clearing the water pump).

NOTE: Timing cover bolts vary in length. Make sure that the proper

2.0L DOHC 4-CYL - VINS [R,U]

Article Text (p. 18)

1991 Mitsubishi Eclipse

For chip

Copyright © 1998 Mitchell Repair Information Company, LLC

Tuesday, March 27, 2001 05:52PM

size bolts are installed in the correct hole locations. See Fig. 24.

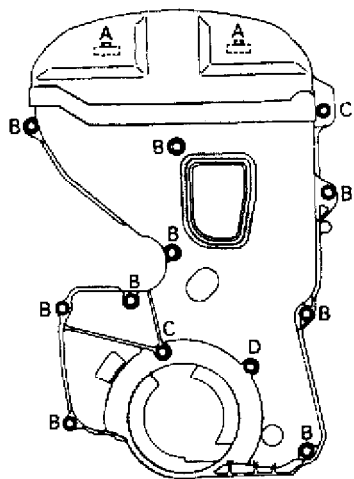

Thread diameter	
× thread length	
A:	6 × 16 (.24 × .63)
B:	6 × 18 (.24 × .70)
C:	6 × 25 (.24 × .98)
D:	6 × 28 (.24 × 1.10) mm (in.)

94C50056

Fig. 24: Timing Cover Bolt Locations and Dimensions
 Courtesy of Mitsubishi Motor Sales of America.

20) Install crankshaft pulley and torque to 25 ± 5 Nm (18 ± 4 ft. lbs.).

21) Install A/C tensioner bracket with A/C belt and torque to 25 ± 2 Nm (18 ± 4 ft.lbs.). Adjust belt tension to 5.5-6.0 mm (.220-.240 in.) belt deflection.

22) Install water pump pulley. Install alternator/water pump and power steering drive belts and adjust belt tension. See the BELT TENSION SPECIFICATIONS TABLE.

BELT TENSION SPECIFICATIONS TABLE

AA

Application	Belt Deflection
-------------	-----------------

Alternator/Water Pump Belt	9.0-11.5 mm (.354-.453 in.)
---------------------------------	-----------------------------

Power Steering Belt	6.0-9.0 mm (.240-.354 in.)
---------------------------	----------------------------

AA

23) Install left front engine mount and bracket and torque to the specifications shown in Fig. 5.

24) Remove engine support fixture. Install lower engine compartment splash shield.

2.0L DOHC 4-CYL - VINS [R,U]

Article Text (p. 19)

1991 Mitsubishi Eclipse

For chip

Copyright © 1998 Mitchell Repair Information Company, LLC

Tuesday, March 27, 2001 05:52PM

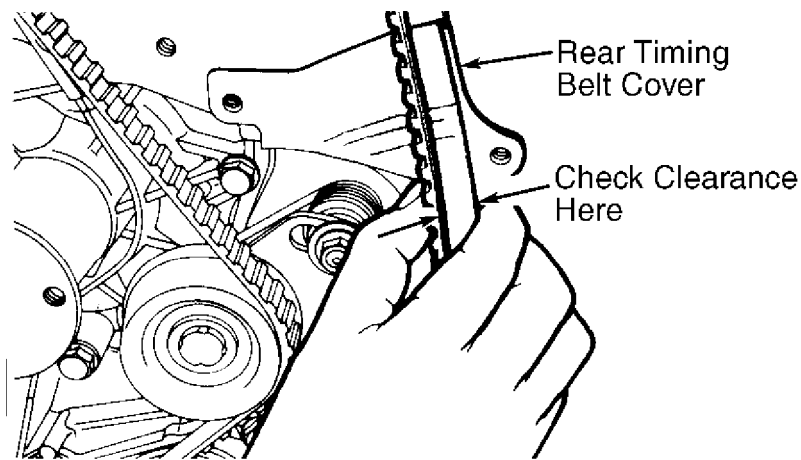

90D02595

Fig. 25: Checking Timing Belt "A" Tension (Typical)
Courtesy of Mitsubishi Motor Sales of America.

ROCKER ARM & VALVE LASH ADJUSTER

CAUTION: DO NOT rotate crankshaft if timing belt has been removed.
DO NOT rotate crankshaft counterclockwise (as viewed from timing belt end of engine).

Removal

- 1) Disconnect throttle cable bracket from intake plenum. Remove timing belt. See TIMING BELT under REMOVAL & INSTALLATION.
- 2) Remove crank angle sensor. See Fig. 26. Secure exhaust camshaft at hex using wrench, and remove sprocket bolt and sprocket. Repeat procedure for intake cam. Loosen front camshaft bearing cap bolts uniformly in 3 steps. Remove caps and seals.
- 3) Repeat procedure for remaining camshaft bearing cap bolts. Remove rear bearing caps last. Remove remaining camshaft bearing caps. If necessary, tap bearing cap using plastic hammer to break loose. Remove intake and exhaust camshafts. Remove rocker arms and lash adjusters from cylinder head.

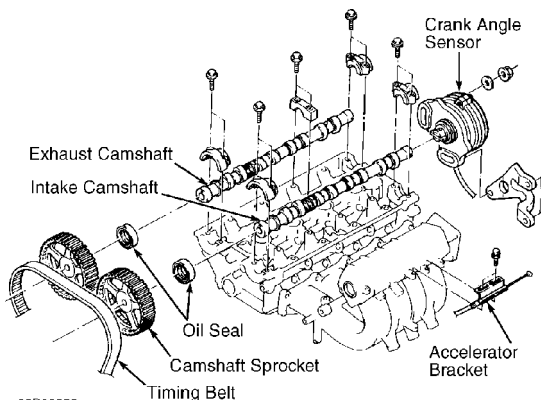

90B002R2

Fig. 26: Exploded View of Camshaft & Related Components
Courtesy of Mitsubishi Motor Sales of America.

2.0L DOHC 4-CYL - VINS [R,U]

Article Text (p. 20)

1991 Mitsubishi Eclipse

For chip

Copyright © 1998 Mitchell Repair Information Company, LLC

Tuesday, March 27, 2001 05:52PM

Inspection

Check rocker arm friction surfaces for wear and damage. Check rocker arm rollers for smooth rotation. Check camshaft journal diameter and lobe height. Replace camshaft if journal diameter and lobe height are not within specification. See CAMSHAFT SPECIFICATIONS table under ENGINE SPECIFICATIONS.

Installation

1) If new camshafts are being installed, check for smooth rotation by installing camshaft in cylinder head without rocker arms. Lubricate journals, and install bearing caps. New camshafts should turn easily by hand. If camshafts are okay, remove bearing caps and camshafts.

2) Install lash adjusters and rocker arms on cylinder head. Lubricate camshaft lobes and bearing journals. Install camshafts in cylinder head with dowel pins at 12 o'clock position. Note intake camshaft is slotted at rear. See Fig. 27.

3) Install camshaft bearing caps in original location, and tighten in sequence in 2-3 steps. See Fig. 28. See the TORQUE SPECIFICATIONS table.

4) Lubricate inside diameter of camshaft oil seal. Using Seal Installer (MD998306 and MD998307), install camshaft oil seal. To complete installation, reverse removal procedure.

CAUTION: Install crank angle sensor so mark on housing aligns with notch on plate; otherwise, incorrect fuel and ignition timing will result. See Fig. 27.

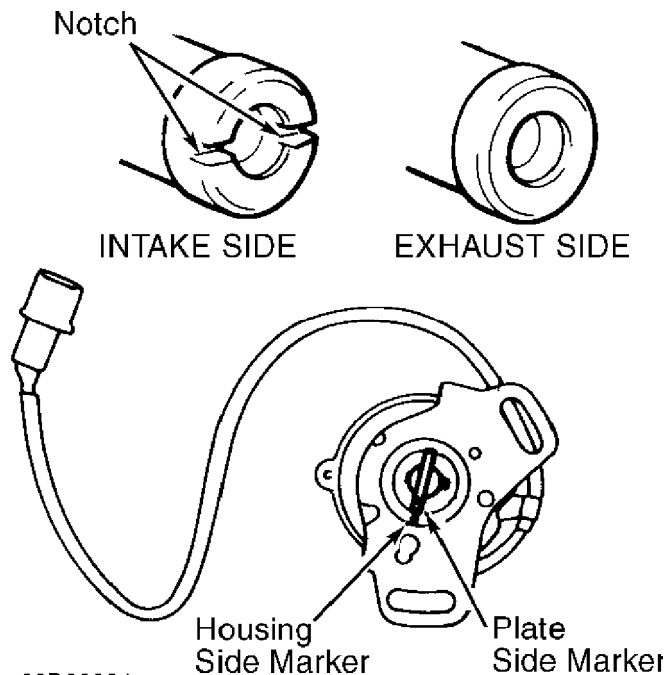

90D00284

Fig. 27: Aligning Crank Angle Sensor to Intake Camshaft
Courtesy of Mitsubishi Motor Sales of America.

2.0L DOHC 4-CYL - VINS [R,U]

Article Text (p. 21)

1991 Mitsubishi Eclipse

For chip

Copyright © 1998 Mitchell Repair Information Company, LLC
Tuesday, March 27, 2001 05:52PM

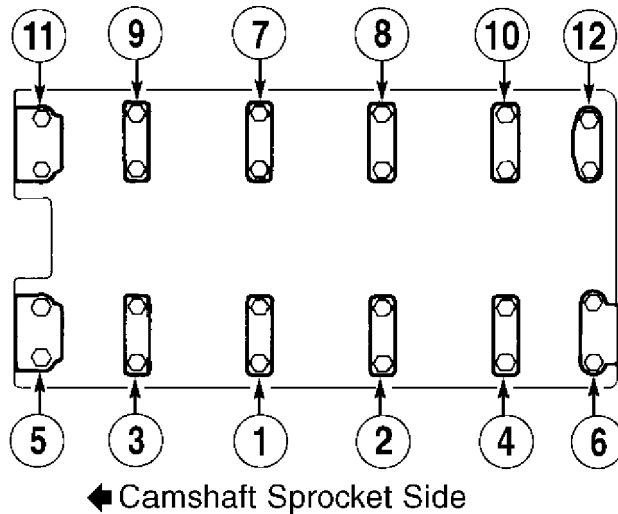

90C00283

Fig. 28: Camshaft Bearing Cap Bolt Tightening Sequence
Courtesy of Mitsubishi Motor Sales of America.

CAMSHAFT

NOTE: For removal and installation of camshaft, see procedures for
ROCKER ARM & VALVE LASH ADJUSTER under REMOVAL &
INSTALLATION.

SILENT SHAFTS & BEARINGS

Removal

Remove front cover and oil pump. See OIL PUMP & FRONT COVER
under ENGINE OILING. Remove silent shafts from cylinder block.

NOTE: Rear bearing(s) cannot be removed unless front bearings have
been removed from block.

Inspection

1) Inspect silent shaft and bearings for damage. Ensure
silent shaft journal O.D. and oil clearance is within specification.
See SILENT SHAFT SPECIFICATIONS table. Replace components if not
within specification.

2) If bearings need replacing, use indicated puller. See
SILENT SHAFT BEARING REMOVAL & INSTALLATION table.

NOTE: Install rear bearings before installing front bearings.

Installation

1) Coat bearing outer area with engine oil before installing.
Mount rear silent shaft bearing on indicated installer. See the
SILENT SHAFT BEARING REMOVAL & INSTALLATION table.

2) Ensure oil hole in bearing aligns with oil hole in
cylinder block. Note left rear bearing does not have oil hole. Install
rear bearings in cylinder block.

3) Repeat procedure for front bearings. Install balance

2.0L DOHC 4-CYL - VINS [R,U]

Article Text (p. 22)

1991 Mitsubishi Eclipse

For chip

Copyright © 1998 Mitchell Repair Information Company, LLC

Tuesday, March 27, 2001 05:52PM

shafts in original location. To complete installation, reverse removal procedure.

SILENT SHAFT SPECIFICATIONS TABLE

AA

Application	Specification
	In. (mm)

Left Silent Shaft

Journal O.D.

Front7270-.7276 (18.466-18.481)

Rear 1.6126-1.6132 (40.959-40.975)

Oil Clearance

Front Journal0008-.0021 (.020-.053)

Rear Journal0017-.0033 (.042-.083)

Right Silent Shaft

Journal O.D.

Front 1.6519-1.6526 (41.959-41.975)

Rear 1.6122-1.6129 (40.951-35.967)

Oil Clearance

Front Journal0008-.0024 (.020-.061)

Rear Journal0020-.0036 (.051-.091)

AA

SILENT SHAFT BEARING REMOVAL & INSTALLATION

AA

Application	Tool No.
-------------	----------

Installer MD990938

Front & Rear Bearing Adapter MD998373

Left Rear Bearing Guide Plate MD998374

Puller MIT304204

Front Bearing Adapter MD998371

Rear Bearing Adapter MD998372

Left Rear Bearing Guide Plate MD998374

AA

REAR CRANKSHAFT OIL SEAL

Removal

1) Remove transaxle/transmission. On M/T models, see CLUTCH article. On A/T models, see TRANSMISSION REMOVAL & INSTALLATION - A/T article in TRANSMISSION SERVICING.

2) Remove flywheel or drive plate. Remove rear main oil seal case and gasket from rear of cylinder block. Remove oil separator and oil seal from seal case.

Installation

1) To install, coat seal lip with oil. Using Seal Installer (MD998376), install seal in seal case until it bottoms.

2) Install oil separator in seal case, with hole of separator at bottom of seal case (toward oil pan). Install seal case and gasket. Install flywheel or drive plate. To complete installation, reverse

2.0L DOHC 4-CYL - VINS [R,U]

Article Text (p. 23)

1991 Mitsubishi Eclipse

For chip

Copyright © 1998 Mitchell Repair Information Company, LLC

Tuesday, March 27, 2001 05:53PM

removal procedure.

WATER PUMP

CAUTION: Note length and location of bolts during removal. Different length bolts are used and must be installed in original location.

Removal

Drain cooling system. Remove necessary coolant hoses. Remove timing belt. See TIMING BELT under REMOVAL & INSTALLATION. Remove water pump mounting bolts. Note bolt length and location. Remove water pump.

Installation

To install, reverse removal procedure using new gasket and "O" ring. Install "O" ring on coolant pipe, and apply water to "O" ring. DO NOT apply grease or oil to "O" ring. Ensure bolts are installed in original location.

OIL PAN

Removal

1) Drain engine oil. On Galant 4WD, disconnect exhaust pipe at manifold. Disconnect and remove transaxle shaft at cylinder block. See AXLE SHAFTS - FRONT article in DRIVE AXLES.

2) On all models, remove oil pan bolts. Using Gasket Cutter (MD998727), cut gasket along sealing surface of cylinder block. Remove oil pan and gasket.

Installation

To install, apply sealant to oil pan flange at timing chain case and rear seal case areas. Install oil pan and gaskets. To complete installation, reverse removal procedure. Tighten bolts to specification. See the TORQUE SPECIFICATIONS table.

OVERHAUL

CYLINDER HEAD

Inspect cylinder head for warpage at deck surface. Resurface cylinder head if warpage exceeds specification. See CYLINDER HEAD SPECIFICATIONS table under ENGINE SPECIFICATIONS.

VALVE SPRINGS

Inspect valve spring free length, out-of-square and installed height. Replace valve spring if not within specification. See the VALVES & VALVE SPRINGS table under ENGINE SPECIFICATIONS. Installed height of spring is measured between spring seat and valve retainer. Install all valve springs with painted area toward rocker arm.

VALVE STEM OIL SEALS

2.0L DOHC 4-CYL - VINS [R,U]

Article Text (p. 24)

1991 Mitsubishi Eclipse

For chip

Copyright © 1998 Mitchell Repair Information Company, LLC

Tuesday, March 27, 2001 05:53PM

DO NOT reuse oil seals. Install valve spring seat before installing oil seals. To provide proper positioning of oil seal, install new oil seals using Valve Seal Installer (MD998737).

VALVE GUIDES

Ensure valve stem diameter is within specification. Check valve stem clearance. Clearance should be within specification. See the VALVES & VALVE SPRINGS SPECIFICATIONS table and the CYLINDER HEAD SPECIFICATIONS table under ENGINE SPECIFICATIONS. If clearance exceeds service limits, replace valve guide with an oversized valve guide.

VALVES

Ensure valve stem diameter and margin are within specification. See VALVES & VALVE SPRINGS SPECIFICATIONS table under ENGINE SPECIFICATIONS.

VALVE TRAIN OVERHAUL

ROCKER ARM SHAFT ASSEMBLY

1) For reassembly reference, note location and order of assembly for all components. Remove bolts from shafts, and separate components. Note length of springs. Intake rocker arm shaft springs are longer than exhaust rocker arm shaft springs. Inspect components for wear and damage.

2) Install components in original location when reassembling shaft assembly. Tighten rocker arm assembly bolts to specification. See the TORQUE SPECIFICATIONS table.

LASH ADJUSTERS

Before installing lash adjuster, submerge lash adjuster in diesel fuel. Use a small wire to hold down internal check valve. Pump plunger up and down 4 or 5 times to bleed air from lash adjuster.

CYLINDER BLOCK ASSEMBLY OVERHAUL

PISTON & ROD ASSEMBLY

1) Mark piston and rod assembly with corresponding cylinder number before removing. Center piston pin in piston. Measure and record piston pin installation depth. Use Piston Pin Removal & Installation Set (MD998184) with hydraulic press to remove piston pin.

2) Piston pin should be easily pushed into piston. If looseness or resistance is encountered, replace piston and pin as a set. Check connecting rod for damage and excessive bend and twist. See the CONNECTING RODS SPECIFICATIONS table in ENGINE SPECIFICATIONS.

3) Position piston, piston pin and rod on press. Ensure front

2.0L DOHC 4-CYL - VINS [R,U]

Article Text (p. 25)

1991 Mitsubishi Eclipse

For chip

Copyright © 1998 Mitchell Repair Information Company, LLC

Tuesday, March 27, 2001 05:53PM

mark on piston will face timing belt side of engine when installed. Using piston pin removal and installation set, install piston pin into piston and rod to depth recorded in step 1). Ensure piston pin is centered in rod and piston.

4) Press load should not exceed 1653-3858 lbs. (750-1750 kg). If press load exceeds specification, replace piston pin and/or connecting rod.

FITTING PISTONS

1) Measure piston skirt diameter at 90-degree angle to piston pin. If piston diameter is not within specification, replace piston. See PISTONS, PINS & RINGS SPECIFICATIONS table under ENGINE SPECIFICATIONS.

2) Measure cylinder bore diameter at 3 places: .47" (12 mm) from top of bore, .47" (12 mm) from bottom of bore and near center of bore. If cylinder bore diameter or taper is not within specification, machine cylinder bore.

3) If piston-to-cylinder bore clearance is not within specification, replace piston and/or machine cylinder bore.

PISTON RINGS

Ensure ring end gap and side clearance are within specification. See PISTONS, PINS & RINGS SPECIFICATIONS table under ENGINE SPECIFICATIONS. DO NOT use a ring expander to install oil ring side rails. Properly position ring end gaps around circumference of piston before installing. See Fig. 29.

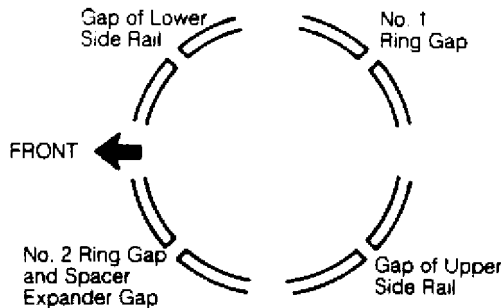

Fig. 29: Positioning Piston Ring Gaps
Courtesy of Chrysler Motors.

ROD BEARINGS

Note position of connecting rod in relation to bearing cap before removing. Ensure bearing oil clearance and side play are within specification. See CRANKSHAFT, MAIN & CONNECTING ROD BEARINGS SPECIFICATIONS and CONNECTING RODS SPECIFICATIONS tables under ENGINE SPECIFICATIONS.

CRANKSHAFT & MAIN BEARINGS

1) Check diameter of crankshaft main bearing and connecting

2.0L DOHC 4-CYL - VINS [R,U]

Article Text (p. 26)

1991 Mitsubishi Eclipse

For chip

Copyright © 1998 Mitchell Repair Information Company, LLC

Tuesday, March 27, 2001 05:53PM

rod bearing journals. Check journals for taper/out-of-round. Check crankshaft end play. See CRANKSHAFT, MAIN & CONNECTING ROD BEARINGS SPECIFICATIONS table under ENGINE SPECIFICATIONS.

2) Tighten main bearing caps (in 2 steps) to specification, starting at center and working outward.

THRUST BEARING

Replace thrust bearing if crankshaft end play is not within specification. See CRANKSHAFT, MAIN & CONNECTING ROD BEARINGS SPECIFICATIONS table under ENGINE SPECIFICATIONS.

CYLINDER BLOCK

1) Check cylinder block head surface warpage. If warpage exceeds specification, machine surface. See CYLINDER BLOCK SPECIFICATIONS table under ENGINE SPECIFICATIONS. DO NOT remove more than a combined total .008" (0.20 mm) material from original surfaces of cylinder head or cylinder block.

2) Check cylinder bore wear and taper. Measure cylinder bore diameter at 3 places: .47" (12 mm) from top of bore, .47" (12 mm) from bottom of bore and near center of bore. If cylinder bore diameter or taper is not within specification, machine cylinder bore. See the CYLINDER BLOCK SPECIFICATIONS table under ENGINE SPECIFICATIONS.

ENGINE OILING

ENGINE LUBRICATION SYSTEM

Oil pressure is provided by a belt-driven oil pump mounted in front cover. Pressure relief valve is not adjustable and located either in front cover or oil filter bracket. See Fig. 30.

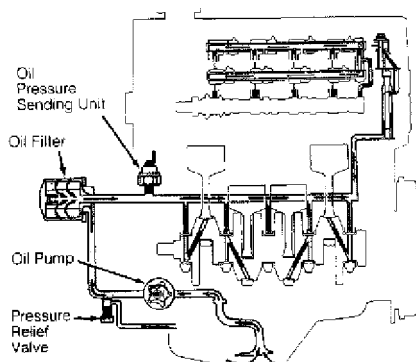

Fig. 30: Engine Oiling System (Typical)
Courtesy of Mitsubishi Motor Sales of America.

CRANKCASE CAPACITY SPECIFICATIONS

AA

Application (1) Qts. (L)

2.0L 4.6 (4.4)

2.0L DOHC 4-CYL - VINS [R,U]

Article Text (p. 27)

1991 Mitsubishi Eclipse

For chip

Copyright © 1998 Mitchell Repair Information Company, LLC

Tuesday, March 27, 2001 05:53PM

(1) - Includes oil filter.

AA

OIL PRESSURE

Oil pressure should be at least 11.4 psi (.80 kg/cm²) at curb idle and oil temperature of 167-194°F (75-90°C).

OIL PUMP & FRONT COVER

Removal

1) Remove timing belt and sprockets. See TIMING BELT under REMOVAL & INSTALLATION. Remove oil pan. See OIL PAN under REMOVAL & INSTALLATION. Remove oil filter. Using Socket (MD998054), remove oil pressure switch.

2) Remove oil pressure gauge sending unit. On turbo models, remove oil cooler and oil cooler by-pass valve. Remove oil jets and check valves from cylinder block. On all models, remove oil pick-up tube. Remove oil filter bracket and gasket.

3) Remove plug, gasket, spring and relief plunger. Using Plug Cap Wrench (MD998162), remove plug cap and "O" ring from front cover.

4) Remove plug from side of cylinder block, and install a .31" (8.0 mm) diameter Phillips screwdriver to hold left silent shaft. See Fig. 31. Remove oil pump driven gear-to-silent shaft bolt.

5) Remove front cover and gasket from cylinder block. Remove silent shaft and crankshaft oil seals from front cover. Remove oil pump cover. Note timing marks on oil pump gears, and remove gears from front cover.

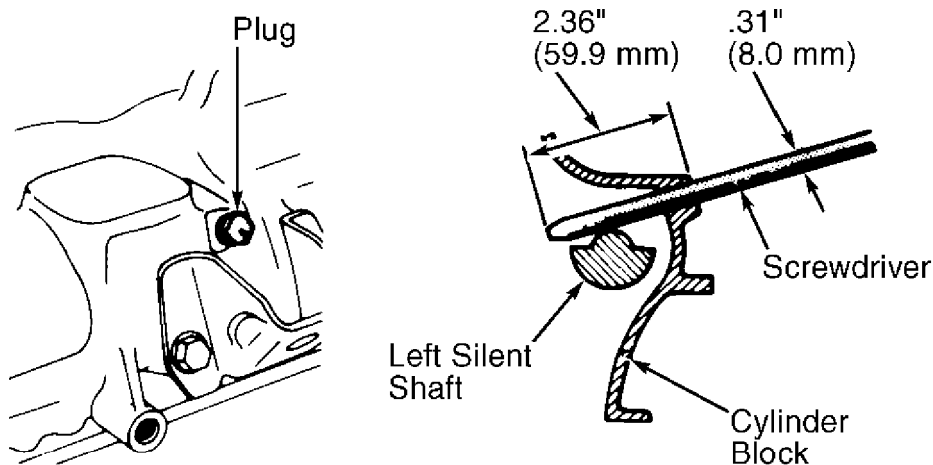

90C02590

Fig. 31: Holding Silent Shaft in Stationary Position
Courtesy of Mitsubishi Motor Sales of America.

Inspection

1) Inspect components for damage. Install oil pump gears in front cover. Using feeler gauge, measure gear-to-front cover clearance between tip of teeth on each gear and front cover.

2.0L DOHC 4-CYL - VINS [R,U]

Article Text (p. 28)

1991 Mitsubishi Eclipse

For chip

Copyright © 1998 Mitchell Repair Information Company, LLC

Tuesday, March 27, 2001 05:53PM

2) Place straightedge across front cover above oil pump gears. Using feeler gauge, check gear side clearance between straightedge and both oil pump gears. Check for ridge on oil pump cover in gear operating area.

3) Ensure relief plunger slides freely in bore. Check free length and spring pressure of relief plunger spring. Replace components if not within specification. See OIL PUMP SPECIFICATIONS table.

4) On turbo models, ensure oil cooler by-pass valve slides freely. Measure distance from valve body to tip of valve at room temperature. Distance should be 1.358" (34.49 mm). Heat oil to 212°F (100°C), and submerge valve in heated oil for a few minutes.

5) Remove valve, and measure distance from valve body to tip of valve. Distance should be at least 1.57" (39.88 mm). Replace valve assembly if measurements are not as specified. Ensure oil jets and check valves are not clogged or damaged.

Installation

1) Lubricate oil pump gears with engine oil, and install. Ensure timing marks are aligned. Install oil pump cover, and tighten bolts to specification. See TORQUE SPECIFICATIONS table.

2) If crankshaft oil seal was removed, use Seal Installer (MD998375) to install seal in front cover. Use a socket of proper diameter to install silent shaft oil seals.

3) Position Oil Seal Guide (MD998285) over front of crankshaft. Lubricate crankshaft oil seal and oil seal guide with engine oil. Install front cover with new gasket, and temporarily tighten bolts. Install oil filter bracket. Ensure bolts of appropriate length are installed.

4) To complete installation, reverse removal procedure. Install plug cap using new "O" ring, and tighten to specification. Apply thread sealant to oil pressure switch threads before installing. Tighten all bolts to specification. See TORQUE SPECIFICATIONS table.

OIL PUMP SPECIFICATIONS TABLE

AA

Application Specification

Gear Side Clearance

Drive Gear

Standard0031-.0055" (.079-.140 mm)

Limit0098" (.249 mm)

Driven Gear

Standard0024-.0047" (.061-.119 mm)

Limit0098" (.249 mm)

Gear-To-Front Cover Clearance

Drive Gear

Standard0063-.0083" (.160-.211 mm)

Limit0098" (.249 mm)

Driven Gear

Standard0051-.0071" (.130-.180 mm)

Limit0098" (.249 mm)

2.0L DOHC 4-CYL - VINS [R,U]

Article Text (p. 29)

1991 Mitsubishi Eclipse

For chip

Copyright © 1998 Mitchell Repair Information Company, LLC

Tuesday, March 27, 2001 05:53PM

Relief Plunger Spring

Free Length 1.835" (46.61 mm)

Spring Pressure 13.4 lbs.@1.579" (6.1 kg@40.11 mm)

AA

TORQUE SPECIFICATIONS

TORQUE SPECIFICATIONS TABLE

AA

Application Ft. Lbs. (N.m)

A/C Tensioner Pulley Bracket Bolt 17-20 (23-27)

Auto Tensioner Bolt 14-20 (19-27)

Camshaft Bearing Cap Bolt (1) 14-15 (19-20)

Camshaft Sprocket Bolt 58-72 (79-98)

Connecting Rod Nut 36-38 (49-52)

Crankshaft Pulley Bolt 14-22 (19-30)

Crankshaft Sprocket Bolt 80-94 (109-127)

Cylinder Head Bolt (2) 80 (110)

Engine Support Bracket Bolt

Front 36-51 (49-69)

Left 22-30 (30-41)

Exhaust Manifold Nut 18-22 (24-30)

Exhaust Pipe-To-Manifold Nut 22-29 (30-39)

Exhaust Pipe-To-Turbo Nut 29-43 (39-58)

Flywheel/Drive Plate Bolt 94-101 (127-137)

Front Cover Bolt 14-16 (19-22)

Front Tensioner Pulley Bolt 31-40 (42-54)

Idler Pulley Bolt 25-30 (34-41)

Intake Manifold Bolt/Nut

8-mm 11-14 (15-19)

10-mm 22-30 (30-41)

Intake Manifold Stay Bolt 18-22 (24-30)

Main Bearing Cap Bolt 47-51 (64-69)

Oil Cooler By-Pass Valve 37-43 (50-58)

Oil Filter Bracket Bolt 11-16 (15-22)

Oil Jet Bolt 22-25 (30-34)

Oil Pump Cover Bolt 11-13 (15-18)

Oil Pump Driven Gear Bolt 25-29 (34-39)

Oil Pump Pick-Up Tube Bolt 11-16 (15-22)

Oil Pump Sprocket Nut 36-43 (49-58)

Oxygen Sensor 29-36 (39-49)

Plug Cap 14-20 (19-27)

Rear Tensioner Retaining Bolt 11-16 (15-22)

Rocker Arm Assembly Bolts 14-15 (19-20)

Silent Shaft Sprocket Bolt 31-35 (42-47)

Throttle Body Bolt 11-16 (15-22)

Turbo Coolant Line At Turbo Banjo Bolt 25-36 (34-49)

Turbo Coolant Line-To-Engine Flare Nut 29-36 (39-49)

Turbo Oil Pipe-To-Cylinder Block Banjo Bolt .. 10-14 (14-19)

Turbo Oil Pipe-To-Turbo Banjo Bolt 20-25 (27-34)

Turbo-To-Manifold Bolt/Nut 40-47 (54-64)

2.0L DOHC 4-CYL - VINS [R,U]

Article Text (p. 30)

1991 Mitsubishi Eclipse

For chip

Copyright © 1998 Mitchell Repair Information Company, LLC

Tuesday, March 27, 2001 05:53PM

Water Pump Bolt		
Except 8 x 65 mm	10 (14)
8 x 65 mm	15-19 (20-26)
		INCH Lbs. (N.m)
Crank Angle Sensor Nut	84-108 (9-12)
Distributor Nut	84-108 (9-12)
Fuel Rail Bolt	84-108 (9-12)
Oil Pan Bolt	48-72 (5-8)
Oil Pressure Switch	72-108 (8-12)
Rear Crankshaft Oil Seal Case Bolt	84-108 (9-12)
Timing Belt Cover Bolt	84-108 (9-12)
Turbo Oil Drain Line Bolt	72-84 (8-9)
Valve Body Bolt	84-108 (9-12)
Valve Cover Bolt	24-36 (3-4)
Water Pump Pulley Bolt	72-84 (8-9)

(1) - Tighten bolts in sequence. See Fig. 28.

(2) - Tighten bolts in sequence. See Fig. 4.

AA

ENGINE SPECIFICATIONS

GENERAL ENGINE SPECIFICATIONS

GENERAL ENGINE SPECIFICATIONS TABLE

AA

Application	Specification
Displacement	122 Cu. In. (2.0L)
Bore	3.35" (85.1 mm)
Stroke	3.46" (87.9 mm)
Compression Ratio	
Non-Turbo	9.0:1
Turbo	7.8:1
Fuel System	PFI
Horsepower @ RPM	
Non-Turbo	135 @ 6000
Turbo	190 @ 6000
Torque Ft. Lbs. @ RPM	
Non-Turbo	125 @ 3000
Turbo	203 @ 3000

AA

CRANKSHAFT, MAIN & CONNECTING ROD BEARINGS SPECS

CRANKSHAFT, MAIN & CONNECTING ROD BEARINGS SPECS TABLE

AA

Application	Specification
	In. (mm)
Crankshaft End Play	

2.0L DOHC 4-CYL - VINS [R,U]

Article Text (p. 31)

1991 Mitsubishi Eclipse

For chip

Copyright © 1998 Mitchell Repair Information Company, LLC

Tuesday, March 27, 2001 05:53PM

Standard	.0020-.0070	(.051-.178)
Wear Limit	.016	(.41)
Main Bearings		
Journal Diameter	2.244	(57.00)
Journal Out-Of-Round	.0006	(.015)
Journal Taper	.0002	(.005)
Oil Clearance		
Standard	.0008-.0020	(.020-.051)
Wear Limit	.004	(.10)
Connecting Rod Bearings		
Journal Diameter	1.771	(45.00)
Journal Out-Of-Round	.0006	(.015)
Journal Taper	.0002	(.005)
Oil Clearance		
Standard	.0008-.0020	(.020-.051)
Wear Limit	.004	(.10)

AA

CONNECTING RODS SPECIFICATIONS

CONNECTING RODS SPECIFICATIONS TABLE

AA

Application	Specification
	In. (mm)
Maximum Bend	.0020 Per 3.937 (.051 Per 100.00)
Maximum Twist	.0039 Per 3.937 (.099 Per 100.00)
Side Play	
Standard	.0039-.0098 (.099-.249)
Wear Limit	.016 (.41)

AA

PISTONS, PINS & RINGS SPECIFICATIONS

PISTONS, PINS & RINGS SPECIFICATIONS TABLE

AA

Application	Specification
	In. (mm)
Pistons	
Clearance	
Non Turbo	.0008-.0016 (.020-.041)
Turbo	.0012-.0020 (.030-.051)
Diameter	3.3464 (85.00)
Pins	
Rod Fit	(1)
Rings	
No. 1	
End Gap	
Standard	.0098-.0177 (.249-.449)
Wear Limit	.031 (.79)
Side Clearance	
Standard	.0012-.0028 (.030-.071)

2.0L DOHC 4-CYL - VINS [R,U]

Article Text (p. 32)

1991 Mitsubishi Eclipse

For chip

Copyright © 1998 Mitchell Repair Information Company, LLC

Tuesday, March 27, 2001 05:53PM

Wear Limit004	(.10)
No. 2			
End Gap			
Standard0138-.0197	(.351-.500)
Wear Limit031	(.79)
Side Clearance			
Standard0012-.0028	(.030-.071)
Wear Limit004	(.10)
No. 3 (Oil)			
End Gap			
Standard0079-.0276	(.201-.701)
Wear Limit039	(.99)

(1) - Press fit with load of 1653-3858 lbs. (750-1750 kg).

AA

CYLINDER BLOCK SPECIFICATIONS

CYLINDER BLOCK SPECIFICATIONS TABLE

AA

Application	Specification
Cylinder Bore	
Standard Diameter 3.347 (85.001)
Maximum Taper0004 (.010)
Maximum Out-Of-Round0004 (.010)
Deck Height 11.18 (283.9)
Maximum Deck Warp (1) .002 (.05)

(1) - Combined maximum total grind limit of cylinder head and cylinder block is .008" (.20 mm).

AA

VALVES & VALVE SPRINGS SPECIFICATIONS

VALVES & VALVE SPRINGS SPECIFICATIONS TABLE

AA

Application	Specification
Intake Valves	
Face Angle 45-45.5°
Head Thickness	
Standard040" (1.02 mm)
Wear Limit028" (.71 mm)
Stem Diameter2585-.2591" (6.565-6.581 mm)
Valve Length 4.311" (109.50 mm)
Exhaust Valves	
Face Angle 45-45.5°
Head Thickness	
Standard059" (1.50 mm)
Wear Limit039" (1.00 mm)
Stem Diameter2571-.2579" (6.530-6.551 mm)

2.0L DOHC 4-CYL - VINS [R,U]

Article Text (p. 33)

1991 Mitsubishi Eclipse

For chip

Copyright © 1998 Mitchell Repair Information Company, LLC

Tuesday, March 27, 2001 05:53PM

Valve Length	4.319"	(109.70 mm)
Valve Springs			
Free Length	1.862-1.902"	(47.295-48.311 mm)
Installed Height	1.575-1.614"	(40.01-48.311 mm)
Out-Of-Square			
Standard	Less Than 2 ϕ	
Wear Limit	4 ϕ	

AA

CYLINDER HEAD SPECIFICATIONS

CYLINDER HEAD SPECIFICATIONS TABLE

AA

Application	Specification
Cylinder Head Height 5.197" (132.00 mm)
Maximum Warp (1) .0020" (.051 mm)
Valve Seats	
Intake Valve	
Seat Angle 44-44.5 ϕ
Seat Width035-.051" (.89-1.30 mm)
Exhaust Valve	
Seat Angle 44-44.5 ϕ
Seat Width035-.051" (.89-1.30 mm)
Valve Guides	
Intake Valve	
Guide Length 1.791" (45.49 mm)
Valve Stem-To-Guide Oil Clearance	
Standard0008-.0019" (.020-.048 mm)
Wear Limit004" (.10 mm)
Exhaust Valve	
Guide Length 1.988" (50.50 mm)
Valve Stem-To-Guide Oil Clearance	
Standard0020-.0033" (.051-.084 mm)
Wear Limit006" (.15 mm)

(1) - Combined maximum total grind limit of cylinder head and cylinder block is .008" (.20 mm).

AA

CAMSHAFT SPECIFICATIONS

CAMSHAFT SPECIFICATIONS TABLE

AA

Application	In. (mm)
End Play004-.008 (.10-.20)
Journal Diameter 1.0217-1.0224 (25.951-25.969)
Lobe Height	
Intake	
Non-Turbo & Turbo M/T 1.3777-1.3974 (34.994-35.494)
Turbo A/T 1.3661-1.3858 (34.699-35.199)

2.0L DOHC 4-CYL - VINS [R,U]

Article Text (p. 34)

1991 Mitsubishi Eclipse

For chip

Copyright © 1998 Mitchell Repair Information Company, LLC

Tuesday, March 27, 2001 05:53PM

Exhaust

Non-Turbo & Turbo A/T 1.3661-1.3858 (34.699-35.199)

Turbo M/T 1.3777-1.3974 (34.994-35.494)

Oil Clearance0020-.0035 (.051-.089)

AA

END OF ARTICLE